

# CAS700/3 AMPLIFIER

*The CAS700/3 Amplifier* is a three channel amplification system delivering 300 watts to the subwoofer(s) and two channels at 200 watts each to the satellite speakers. This system is designed to be used in direct burial or wall mount applications as a 700W amp for stereo systems that require a subwoofer.

**NOTES:**

CAS should always be installed in a shady area if possible.

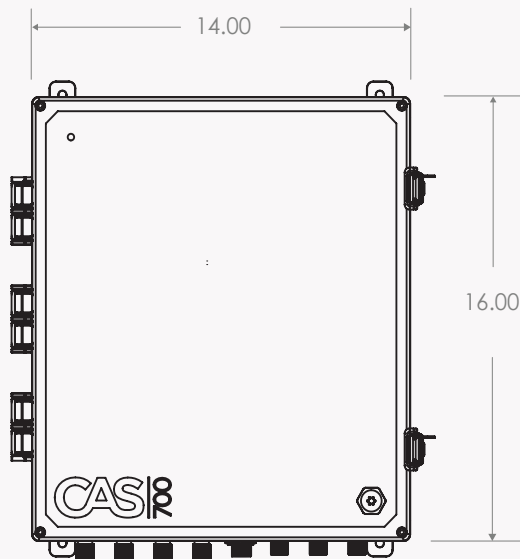

## CAS700/3 AMPLIFIER SPECIFICATIONS

- Size (H x W x D): 16in x 14in x 7in
- Weight: 8 lbs 3 oz (unloaded), 13 lbs 6 oz (loaded)
- Construction: Polycarbonate & Stainless Steel
- Finish: White
- Max Speakers: 10 (2 x 8 ohm sub, 8 x 8 ohm sat)
- Power In: 600W 15VDC (not included)
- Power Out: 700W (300W/CH + 200W/CH + 200W/CH)
- Impedance: Stable to 2 ohms
- Mounting: Direct Burial or Wall (brackets included)
- Speaker Connector: Coastal Connectors (CC & 5P)
- Warranty: 2-Year Limited Warranty

# ORDERING INFORMATION

## FIXTURE

**CAS700/3** (CAS700/3 AMPLIFIER)

---

---

---





---

---

**CAS700/3**

e.g. **CAS700/3** = CAS700/3 Amplifier

## ACCESSORIES

SKU	ITEM		
CAS500/2	CAS500/2 Amplifier		
CAS500/3	CAS500/3 Amplifier		
SAS1PS-KIT	SAS-1 + 24V DC Power Supply	 SAS-1	 24V DC Power Supply